

UTILITY VENT SET FAN  
 UVS2, CLASS1, CONTROL DAMPER

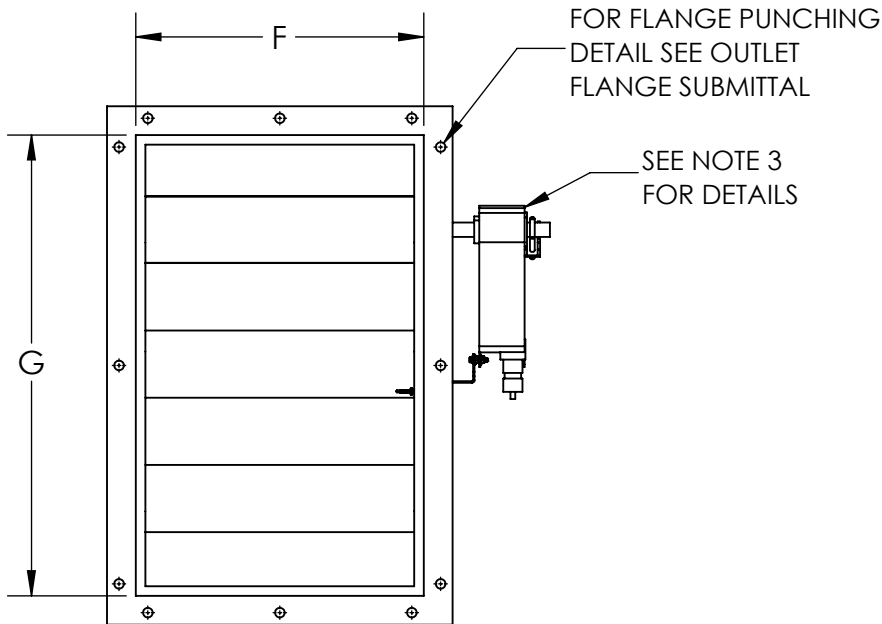

**BACK VIEW  
 (BLADES OPEN)**

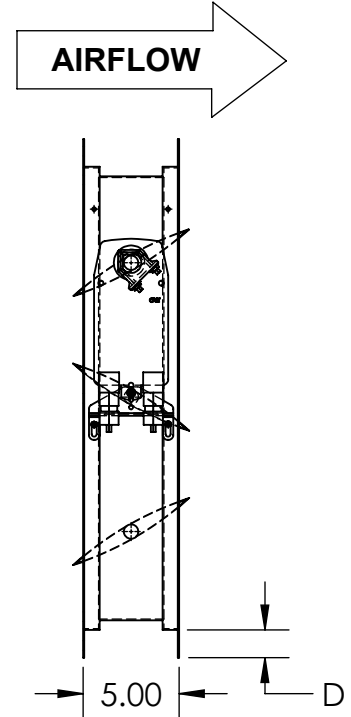

**SIDE VIEW  
 (BLADES OPEN)**

MODEL SIZES	'D'	'F'(100% W)	'F'(80% W)	'F'(50% W)	'G'
060	1.5	8.19	-	-	11.56
070	1.5	8.19	-	-	11.56
080	1.5	8.19	-	-	11.56
105	1.5	8.19	-	-	11.56
122	1.5	9.88	9.25	-	13.06
135	1.5	10.88	10.19	-	14.38
150	1.5	12.06	11.31	-	15.88
165	1.5	13.25	12.44	-	17.56
182	1.5	14.06	13.09	11.63	20.06
200	1.75	15.38	14.38	12.75	22.00
222	1.75	17.13	16.00	14.13	24.50
245	1.75	18.75	17.50	15.63	27.00
270	1.75	20.63	19.38	17.13	29.75
300	1.75	23.00	21.50	19.13	32.88
330	1.75	25.25	23.63	21.00	36.19
365	1.75	27.88	26.13	23.25	40.06
402	2.00	30.75	28.88	25.63	44.13
445	2.00	34.00	31.88	28.25	48.75
490	2.00	37.50	35.13	31.13	53.50
542	2.00	41.50	38.88	34.50	59.19

**NOTES :**

1. Control Damper to be double flanged, punched, and opposed airfoil bladed.
2. Galvanized and extruded Aluminum construction.
3. NEMA 2, Spring Return Actuator, Fail Open, 2 SPDT Auxiliary Limit Switch, available in 24V, 115V, or 230V.
4. Shipped loose.

ALL DIMENSIONS ARE IN INCHES

REVISION:

FORM:

REPLACES: